

#1078 or #1079

INSTRUCTIONS

Water supply to DISHMASTER must be turned off to make this replacement.

1. Remove screws & pull handles forward to remove.

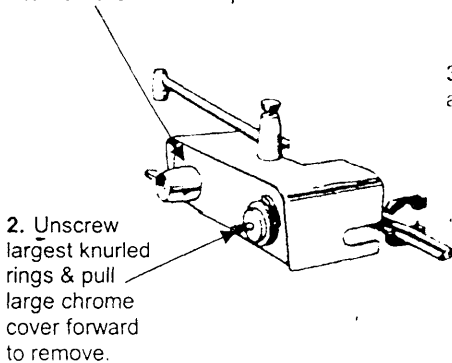

3. Push out to remove hose assembly from cover

CAUTION:
Lubricate all O-rings with vegetable oil before assembly

4. With both valves CLOSED, remove the knurled retaining nuts and pull straight out to remove stem assemblies.

5. Remove the red or blue bushing from the old stem and screw on to the new stem until it touches the stem end. UNSCREW EACH APPROXIMATELY ¼ TURN. Push stem assemblies straight in to the body, engaging the 2 lugs on the bushings into the slots in the body. Replace the original knurled retaining nuts.

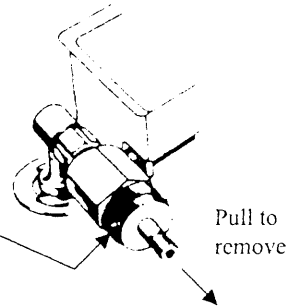

NOTES:

- Clean detergent tank before re-assembly.
- Lubricate O-rings with vegetable oil before assembly.
- Follow step 11 on page 2 of your service manual for correct setting of valve handles.
- RED – hot water (left side)
- BLUE – cold water (right side)